

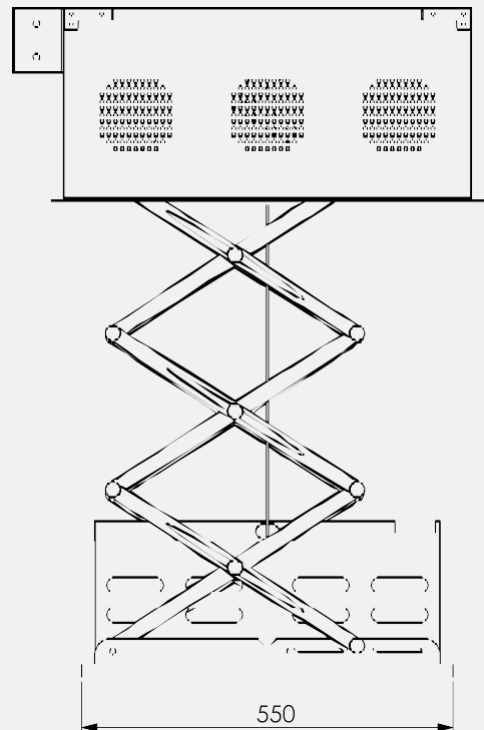

CUBE TYPE LIFT_{KC} 150

Max size of projector 450W x 450D x 180H
 Maximum weight capacity: 15KGS
 Power consumption: 100W
 Voltage: 230 - 240V

- Suitable for conference room, office & homes
- Store, show & service position
- Limits setting allows from the ground
- Wireless RF remote control
- Full cable management
- Elegant polished aluminium die cast scissor arm

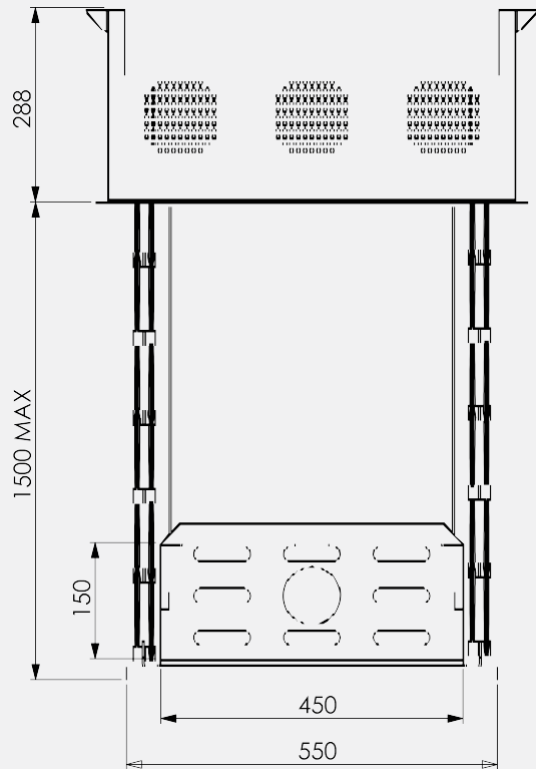
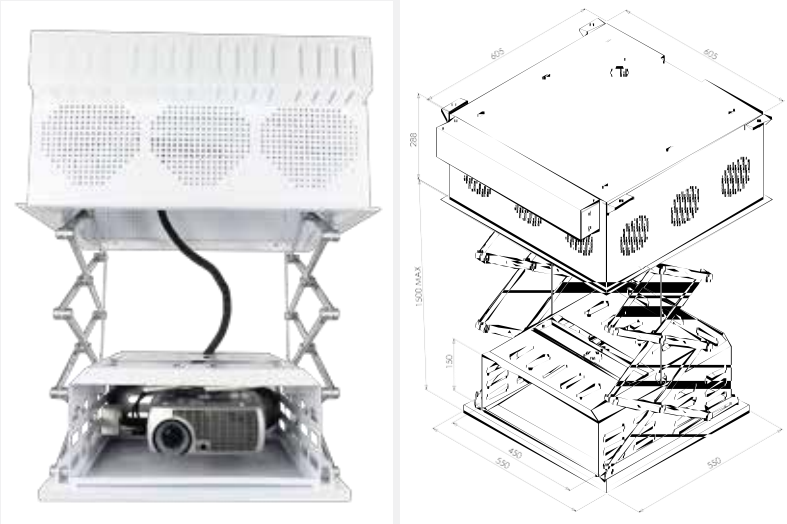

Optional control available



RTS Dry Contact Transmitter



RTS Wireless Wall Switch

*Standard warranty applies, 2 year warranty only for motor