

● Specifications

		NP-PH1202HL	
Method		3 chip DMD reflection type	
Specifications of main parts	Main panel	Size	3 × 0.65" 1080p (aspect ratio: 16:9)
	Projection lenses	Pixels *1	2,073,600 (1,920 dots × 1,080 lines)
		Zoom	Power-adjustable (range depends on lens)
	Light source	Focus	Power-adjustable
		Lens shifting	Power-adjustable (range depends on lens)
Light source (laser diode) Life *2	Normal mode		20,000 H
		ECO1 / ECO2 / Longlife	27,000 H / 40,000 H / 30,000 H
	Optical unit		5 piece prism
Light output **3,4	Normal mode		12,000 lm
		ECO1 / ECO2 / Longlife	Approx. 80 % / 50 % / 90 %
Contrast ratio *4 (all white / all black)		10,000:1 with dynamic contrast	
Screen size		See option lens specifications	
Colour reproducibility		10-bit colour processing (approx. 1.07 billion colours)	
Quietness (ECO2 / ECO1 / Normal mode / Longlife)		43 dB / 45 dB / 47 dB / 55 dB	
Scan rate	Horizontal	Analogue: 15 kHz, 24 to 100 kHz (24 kHz or greater for RGB inputs), conforms to VESA standards Digital: 15 kHz, 24 to 153 kHz, conforming to VESA standards	
		Vertical	Analogue: 48 Hz, 50 to 85 Hz, 100, 120 Hz conforming to VESA standards Digital: 24, 25, 30, 48 Hz, 50 to 85 Hz, 100, 120 Hz conforming to VESA standards
Max. display resolution (horizontal × vertical)		Analogue: 1,920 × 1,200 (with Advanced AccuBlend) / Digital: 4,096 × 2,160 (with Advanced AccuBlend)	
Input / output connectors	Computer / component		Mini D-Sub 15-pin × 1, 5BNC × 1
	HDMI® input terminals		TypeA 19-pin HDMI® connector with HDCP × 1
	HDMI® output terminal		TypeA 19-pin HDMI® connector with HDCP × 1
	HDBaseT™		RJ45 × 1 (IEEE 802.3 / 802.3u 10BASE-T / 100BASE-TX), shared with Ethernet
	DisplayPort™		DisplayPort 20-pin connector × 1
	BNC (CV)		BNC × 1 (shared with computer 5BNC)
	BNC (Y/C)		BNC × 2 (shared with computer 5BNC)
	PC control connector		D-Sub 9-pin × 1
	GPIO		D-sub 37-pin female × 1
	USB port		USB type A × 1
	Ethernet port		RJ-45 × 1, (supports 100BASE-TX, shared with HDBaseT)
	Remote connector		Stereo mini jack × 1
	3D SYNC output terminal		5 V / 10 mA, synchronized signal output for 3D use
	Option slot		OPS type × 1
Usage environment		Operating temperature: 5 to 40 °C *5, operating humidity: 20 to 80 % (with no condensation) Storage temperature: -10 to 50 °C, storage humidity: 20 to 80 % (with no condensation) Operating altitude: 0 to 2,600 m	
Power supply		200 to 240 V AC, 50/60 Hz	
Power consumption	Normal		1,392 W
	ECO1		1,110 W
	ECO2		752 W
	Longlife		1,291 W
	Standby (Normal)		1.83 W
	Standby (HDBaseT)		5.7 W
Rated input current		9.2 A	
Dimensions (W × H × D)		680 × 333 × 860 mm (net dimensions, not including protruding parts)	
Weight		68.0 kg (net weight, not including lens)	

\*1: Effective pixels are more than 99.99 %.  
 \*2: Time at which the laser light source is at half brightness; not a guaranteed time.  
 \*3: Light output value when the [PRESET] mode is set to [HIGH-BRIGHT] and the [LIGHT MODE ADJUST] is set to [100] while using the NP-9LS12ZM1 or NP9LS16ZM1.  
 \*4: Compliant with ISO21118-2005.  
 \*5: When surrounding temperature is 35-40 °C, [PRESET] becomes [ECO] mode automatically.  
 These specifications and the product's design are subject to change without notice.

● Cabinet dimensions

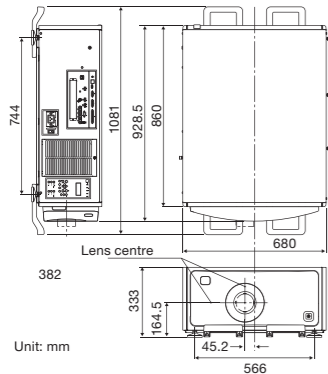

● Lens specifications

Model name	NP-9LS08ZM1	NP-9LS12ZM1	NP-9LS13ZM1	NP-9LS16ZM1	NP-9LS20ZM1	NP-9LS40ZM1
Lens type	Zoom	Zoom	Zoom	Zoom	Zoom	Zoom
Zoom / Focus	Power	Power	Power	Power	Power	Power
Zoom ratio	1.5	1.43	1.58	1.67	1.87	1.56
F (Wide-tele)	2.5 - 3.0	2.5	2.5	2.5	2.5	2.5
f	13.3 - 19.9 mm	18.6 - 26.7 mm	20.7 - 32.7 mm	25.2 - 42.0 mm	32.2 - 60.3 mm	62.1 - 97.8 mm
Throw ratio (1080p)	0.90 - 1.35	1.27 - 1.82	1.41 - 2.23	1.71 - 2.87	2.25 - 4.18	4.31 - 6.77
Screen size	70 - 600	100 - 500	100 - 500	100 - 500	100 - 500	60 - 500
Brightness	11,000 lm	12,000 lm	11,700 lm	12,000 lm	11,800 lm	12,300 lm
Weight	2.25kg	2.36kg	2.34kg	2.36kg	2.28kg	1.7kg

● Remote control  
(Included accessory)



● Options

Lenses

- NP-9LS08ZM1
- NP-9LS12ZM1
- NP-9LS13ZM1
- NP-9LS16ZM1
- NP-9LS20ZM1
- NP-9LS40ZM1

Boards



3G/HD/SD-SDI: SB-04HC  
HD/SD-SDI: SB-01HC

OPS single board controller (computer)



N8000-8865 / N8000-8866  
N8000-8830 / N8000-8822

# Installation Projector PH1202HL

A bright 3-chip DLP laser installation projector delivering all the benefits associated with the latest laser light source technology.



• This product is equipped with a laser module. This product is classified as Class 1 of IEC60825-1 Third edition 2014.  
 • When turning on the projector, make sure no one within projection range is looking at the lens. Do not look into the lens while the projector is on.  
 • Please read the user's manual carefully before using the projector and keep the manual handy for future reference.

NaViSet is a trademark or registered trademark of NEC Display Solutions, Ltd. in Japan, the United States and other countries.  
 DLP and the DLP logo are registered trademarks or trademarks of Texas Instruments.  
 Microsoft is a registered trademark or trademark of Microsoft Corporation in the United States and/or other countries.  
 The terms HDMI and HDMI High-Definition Multimedia Interface, and the HDMI Logo are trademarks or registered trademarks of HDMI Licensing LLC in the United States and other countries.  
 DisplayPort and the DisplayPort Compliance Logo are trademarks owned by the Video Electronics Standards Association in the United States and other countries.  
 HDBaseT and the HDBaseT Alliance logo are trademarks of the HDBaseT Alliance.  
 CRESTRON and CRESTRON ROOMVIEW are trademarks or registered trademarks of Crestron Electronics, Inc.  
 AMX is a trademark or registered trademark of AMX in the United States and other countries.  
 P.LINK trademark is a trademark under application for trademark rights in Japan, the United States of America and other countries and areas.  
 VESA is a trademark of a nonprofit organization, Video Electronics Standard Association  
 All other trademarks are the property of their respective owners.  
 The images in this brochure are samples.  
 All rights reserved. All specifications are subject to change without notice. June 2015



# The PH1202HL presents super dust protection and professional installation features for superior projection performance.

## Advanced installation capabilities

### High brightness and outstanding images

The projector realizes a brightness of 12,000 lumens through use of a high-brightness laser light source, so vivid images are projected in large spaces such as halls and auditoriums. Furthermore, use of a Full-HD (1,920 × 1,080 pixels) 3-chip DLP® that allocates a single DLP® chip to each RGB color realizes high-resolution, largescreen projection that greatly surpasses that of 1-chip types. In addition, a unique high resolution function, 3rd generation contrast enhancement, increases the sense of contrast of the border areas of images to realize more vivid and sharper image projection.

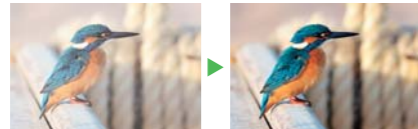

The 3rd generation contrast enhancement function increases the sense of contrast.

### No more lamp replacements

Up to 20,000 hours\* of maintenance-free operation possible due to the laser light source.

\* Actual hours may vary depending on usage conditions. Not a guaranteed time.

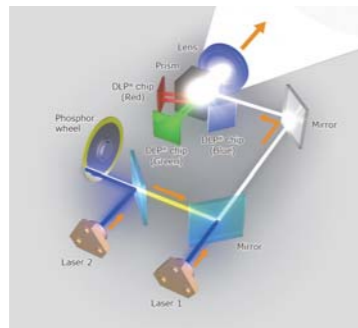

Light source and optical light path image

### A dustproof design supported by NEC's unique closed-loop cooling system

The projector has a dustproof design to prevent the staining of optical components from the ingress of dust and the deterioration of brightness and image quality. Heat within the dustproof unit is exhausted from a heatsink, and the external air used for cooling does not directly contact the optical system, so the design offers both excellent dustproofing and cooling.

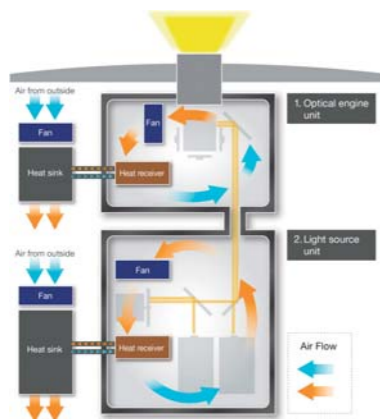

### Tilt-free and portrait installation support

The projector can be rotated freely (360 °) to point up or down depending on the installation requirements and can be rotated (along with the screen if necessary) to a vertical alignment so that portrait content can be viewed without black bars on the sides when landscape mode is used.

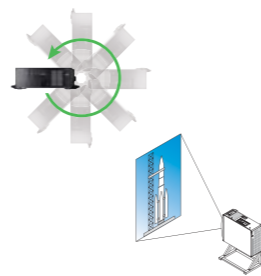

### Built-in edge blending

This function seamlessly blends multiple projected images to display a single high-resolution image.



### Multiscreen function

Multi-display capabilities and tiling technologies are integrated into the PH series. This projector is also equipped with multiple digital input and HDMI output terminals that can connect multiple projectors in a digital daisy chain. These cutting-edge functions produce a beautiful high-resolution image, including a 4K/2K high-resolution display using 4 PH1202HL projectors and various picture in picture / picture by picture configurations.

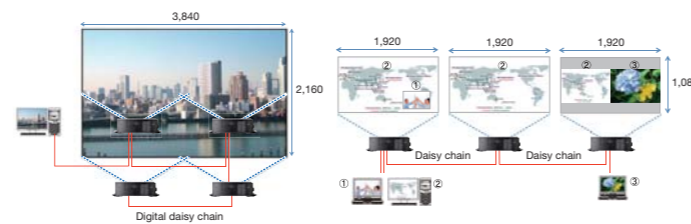

### Geometric Correction

Projection isn't confined to a standard flat screen or wall with the NEC PH series. Geometric correction allows these models to project an image on spheres, cylinders, corner angles and many more non-standard surfaces.



## Fantastic cinema quality picture

### Equipped with NEC's NV1301 4,096 × 2,160 scaler chip and the 3rd-generation contrast enhancement circuit

This 10-bit video processor represents an enormous leap in video processing, with true flagship performance in noise reduction, de-interlacing and scaling.



- 4K Ultra HD support (4,096 × 2,160 / 3,840 × 2,160)
- 12-bit gamma correction
- Advanced colour correction (6-axis saturation and hue adjustment / skin tone)
- Video and film cadence detection (multi-cadence)
- Per-pixel motion adaptive de-interlacing
- Detail enhancement
- Super resolution correction (3rd-generation contrast enhancement)
- 3D random, mosquito and block noise reduction

## Compatible with diverse signal sources

### Built-in HDBaseT support

Simplify your installations with HDBaseT, which is optimized for video applications and supports uncompressed Full HD digital video, audio, Ethernet, and various control signals. With only a single cable (up to 100 m) to run, infrastructure and labor costs are reduced, installations are significantly easier, and there is no cable clutter to manage. With uncompressed HD video support, images have never been more stunning. What's more, control signals are contained in the same cable.



### Wide selection of inputs and outputs such as HDMI and DisplayPort

The projector is equipped with a wide range of input/output terminals and compatible with a variety of image sources, which lets you connect HDMI, DisplayPort, computer (analogue), 5-core BNC, and video sources.



### Expansion Slot

The slot technology allows for the integration of Open Pluggable Specification (OPS\*) boards and other option slot products without the need to store additional external equipment. This offers the greater flexibility customers require.

\*OPS is a standard established by Intel Corporation.

### Terminals

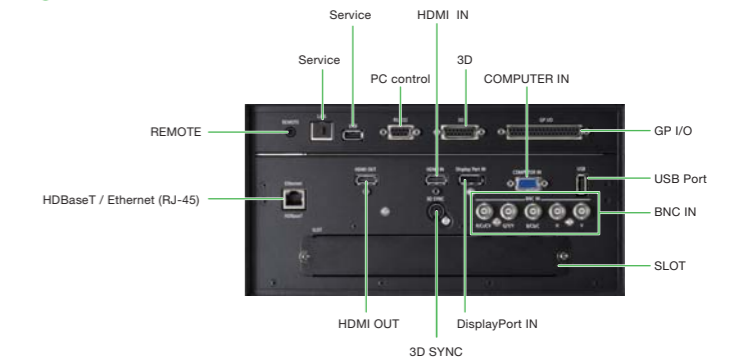

## Other useful functions and features

- Seamless switching
- Lens shutter
- Program timer with real time clock / off timer
- Remote control ID
- Silent design for 43 dB in ECO2 mode
- Direct power on/off, auto power on/off
- PIN security
- Network control

NaViSet Administrator 2 / PC control / Alert mail  
CRESTRON ROOMVIEW™ / AMX BEACON  
PJLink / HTTP server (projector adjustment)



**PH1202HL**

12,000 ANSI lumens Full-HD 68.0 kg\*

\*Not including lens

